

### Application

The SKF Oil levellers, type LAHD, are designed for automatic adjustment of the optimal oil lubrication level in oil bath lubricated applications such as bearing housings, gear boxes and crank cases. They effectively solve the problem of adjusting the correct oil level during running conditions rather than during stand-still. Furthermore, they will automatically compensate for oil leakage and offer the possibility of visual inspection of the oil level. The oil leveller will not compensate if the oil level is too high.

### Description

The oil leveller consists of two communicating oil reservoirs, one on top of the other. The lower reservoir is in direct contact with the application and hence its oil level is the same as the oil level inside the application. Through a ventilation tube the lower reservoir is in direct contact with the ambient air. The upper reservoir is an airtight container storing replacement oil. Through its extended neck, which dips into the oil of the lower reservoir, the two reservoirs are in direct connection with each other. However oil can only flow from the upper to the lower reservoir once the oil level in the lower reservoir goes below the preset level, allowing air to flow through the extended neck to the upper reservoir. Two different types are available, the LAHD 500 with a 500ml oil reservoir and the LAHD 1000 with a 1 000 ml oil reservoir.

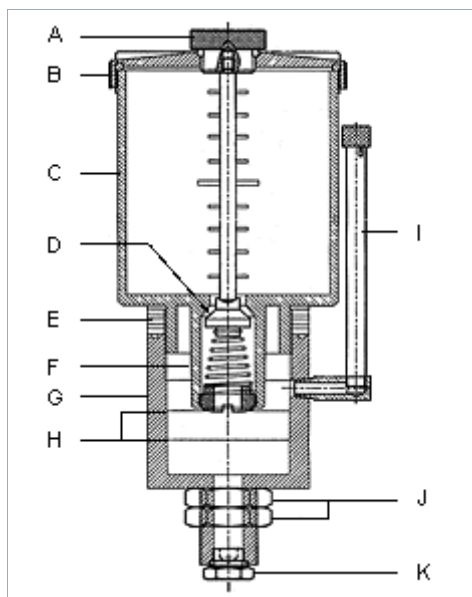

- A Oil inlet
- B Upper cover
- C Upper reservoir
- D Spring loaded valve
- E Set of gaskets
- F Extended neck
- G Lower reservoir
- H Oil level lines
- I Ventilation tube
- J Fixation nuts
- K Magnetic, drainage plug

### Technical data

Designation	LAHD 500 / LAHD 1000
<b>Boundary dimensions</b>	
LAHD 500	Ø 91 mm x 290 mm high (3.6 x 11.4 in)
LAHD 1000	Ø 122 mm x 290 mm high (4.8 x 11.4 in)
<b>Reservoir volume</b>	
LAHD 500	500 ml (17 fl. oz. US)
LAHD 1000	1000 ml (34 fl. oz. US)
<b>Container material</b>	Polycarbonate
<b>Temperature range permitted</b>	- 20 to 125 °C (-5 to 255 °F)
<b>Permissible humidity</b>	0 - 100 %
<b>Length of connecting tube</b>	600 mm (2 feet)
<b>Connection thread</b>	G 1/2
<b>Tube material</b>	Polyurethane
<b>O-ring material</b>	NBR - 70 Shore
<b>Gaskets</b>	NBR - 80 Shore
6 pieces	3 pcs 3 x 64,5 x 82,5 mm 2 pcs 2 x 64,5 x 82,5 mm 1 pcs 2 x 62,5 x 82,5 mm
<b>Other material</b>	Aluminum, Bronze, Stainless Steel
<b>Suitable oil types</b>	Mineral and synthetic oils

