

# SKF Vibracon

The economical machinery mounting solution

## Why use SKF Vibracon?

- SKF Vibracon is a self leveling, height adjustable and re-usable chock.
- Easy and accurate mounting of all types of rotating equipment to base frames, steel foundations or concrete.
- Eliminates soft foot.
- Reduces the cost of equipment foundations by design for the first build or through retrofit.
- SKF Vibracon has many well documented applications and references.
- Wide choice of standard products.

## SKF Vibracon can help save costs in:

- Industrial and energy applications
- Marine and offshore applications
- Military and navy applications

## SKF Vibracon is typically used for:

- Gas and diesel engines
- Compressors
- Electric motors
- Gearboxes
- Generators
- Pumps and fans
- Bearing housings
- Turbines
- Other critical rotating machinery

SKF Vibracon chocks have been rigorously tested both in the laboratory and the field, in all types of environments and applications under the scrutiny of designers, production managers, OEM commissioning engineers, operators and owners. SKF Vibracon works technically and economically for many of the world's best. Contact SKF for application and trial examination.

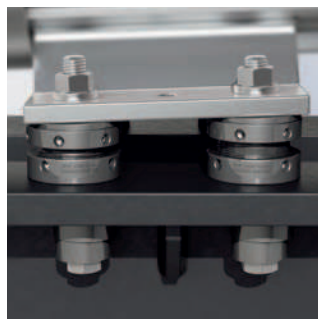
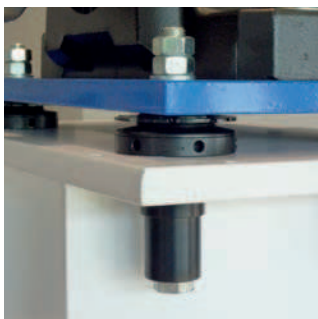
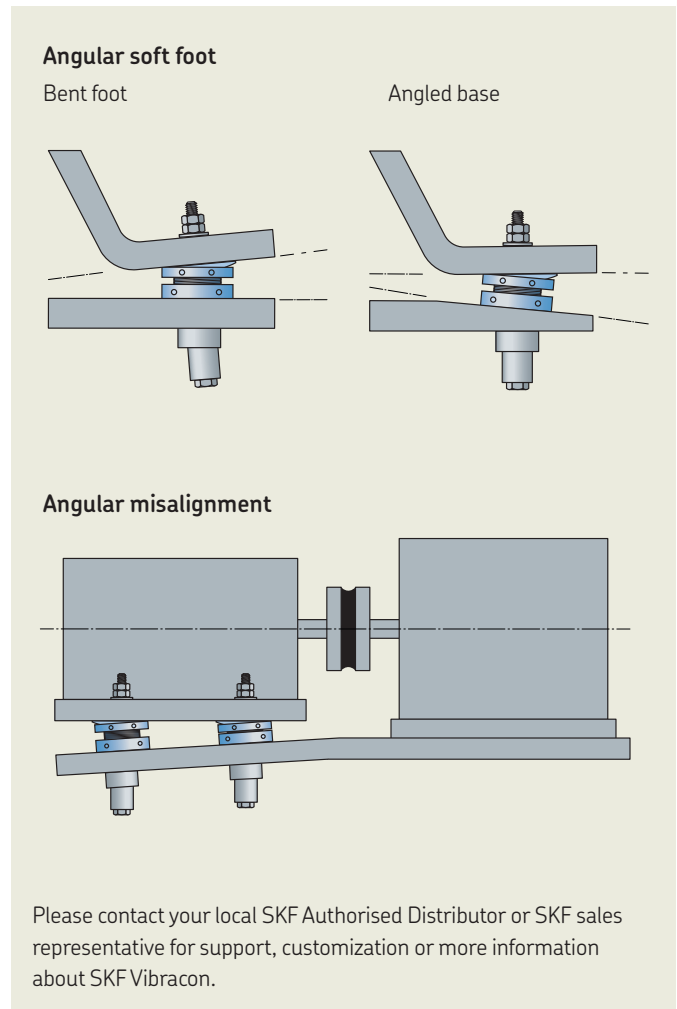



**Carbon steel chocks (-CS)**

The SKF Vibracon adjustable chock has many configurations and material options to satisfy technical concerns, the carbon steel models being suitable for indoor use. Additives are added to the mating surfaces providing initial protection before and during installation and avoid seizing of the parts when rotated. The products provide an economic solution for environmentally less demanding applications, while guaranteeing a lifetime reliable chocking.

**Surface treated chocks (-CSTR)**

Many installations where the SKF Vibracon chocks are applied can be found in tough, humid and salty climates, where protection against corrosion is recommended. To cater for this need, SKF has been testing different solutions resulting in the surface treated SKF Vibracon chock. All parts are treated individually to guarantee an optimal result, consistent quality and extended corrosion protecting capabilities.

**Stainless steel chocks (-SS)**

In harsh conditions, where requirements cannot be met by carbon steel surface treated chocks, the stainless steel chocks will be the solution. Mating surfaces are treated with additives to avoid seizing of the parts when rotated.

**SKF Vibracon low profile (-ASTR)**

The low profile elements offer an economic solution for repair projects or fixed design systems where expensive milled chocks, shims or epoxy resins were applied previously. SKF Vibracon low profile configuration addresses those applications where the chock height between the foundation and component has been established by the previous design. Most of the other chocking methods are time-consuming and do not support the life cycle needs of the machine owners and installation activities on a tight schedule.

**How to select the appropriate SKF Vibracon chock**

**Step 1**  
Diameter of the foundation bolt (M)

**Step 2**  
Available chocking height (A)

**Step 3**  
Check environmental conditions

Vibracon selection tool  
[www.mapro.skf.com/vibracon](http://www.mapro.skf.com/vibracon)  
The SKF Vibracon selection tool provides a calculation tool to determine the most suitable SKF Vibracon chock for your application.

**Technical data**

Designation	M Bolt size	A min. height	A nominal height	A max. height	Min. reduced height 1)	d <sub>1</sub> diameter	d <sub>2</sub> bolt hole	d <sub>k</sub> key holes	Pitch	Mass
	Metric	mm	mm	mm	mm	mm	mm	mm	mm	kg
SM 12 -CS SM 12 -CSTR SM 12 -SS	M12	30	34	38	23	60	17	6	1	0,6
SM 16 -CS SM 16 -CSTR SM 16 -SS	M16	35	40	45	26	80	21	6	1,5	1,2
SM 20 -CS SM 20 -CSTR SM 20 -SS	M20	40	45	50	31	100	25	8	2	2,2
SM 24 -CS SM 24 -CSTR SM 24 -SS	M24	45	51	57	34	120	31	8	2	3,5
SM 30 -CS SM 30 -CSTR SM 30 -SS	M30	50	56	62	39	140	37	10	2	5,3
SM 36 -CS SM 36 -CSTR SM 36 -SS	M36	55	61	67	44	160	44	10	2	7,5
SM 42 -CS SM 42 -CSTR SM 42 -SS	M42	60	66	72	49	190	50	10	2	12,0
SM 48 -CS SM 48 -CSTR SM 48 -SS	M48	70	77	85	56	220	60	10	3	17,0
SM 56 -CS SM 56 -CSTR SM 56 -SS	M56	75	82	90	61	230	66	12	3	23,0
SM 64 -CS SM 64 -CSTR SM 64 -SS	M64	80	87	95	66	250	74	12	3	27,0
SKF Vibracon low profile										
SM 16 LP-ASTR	M16	20	25	30	20	80	21	6	1,5	0,6
SM 20 LP-ASTR	M20	20	25	30	20	100	25	6	2	0,9
SM 24 LP-ASTR	M24	20	25	30	20	120	31	6	2	1,3
SM 30 LP-ASTR	M30	20	25	30	20	140	37	6	2	1,8
SM 36 LP-ASTR	M36	30	35	40	30	160	44	6	2	3,7
SM 42 LP-ASTR	M42	35	40	45	35	190	50	6	2	6,2

1) Minimum reduced height can be reached by machining the centre and bottom part of the SKF Vibracon chock on a lathe.

**Technical data**

Designation	Bolt size	Tightening torque 1)	Bolt size	Tightening torque 1)	Max. bolt size 2)	Machine load 3)	Proof load 4)
	Metric	Nm	Metric	Nm	Metric	kN	kN
SM 12 -CS SM 12 -CSTR SM 12 -SS	M12	85	M14	110	M16	8	160
SM 16 -CS SM 16 -CSTR SM 16 -SS	M16	215	M18	270	M20	15	175
SM 20 -CS SM 20 -CSTR SM 20 -SS	M20	420	M22	500	M24	25	250
SM 24 -CS SM 24 -CSTR SM 24 -SS	M24	730	M27	890	M30	35	420
SM 30 -CS SM 30 -CSTR SM 30 -SS	M30	1 460	M33	1 745	M36	60	600
SM 36 -CS SM 36 -CSTR SM 36 -SS	M36	2 570	M39	3 000	M42	90	775
SM 42 -CS SM 42 -CSTR SM 42 -SS	M42	4 125	M45	4 995	M48	120	1 275
SM 48 -CS SM 48 -CSTR SM 48 -SS	M48	6 210	M52	7 175	M56	160	1 300
SM 56 -CS SM 56 -CSTR SM 56 -SS	M56	10 035	M60	10 360	M64	225	1 750
SM 64 -CS SM 64 -CSTR SM 64 -SS	M64	15 165	M68	16 320	M72	300	1 900
SKF Vibracon low profile							
SM 16 LP-ASTR	M16	215	M18	270	M20	15	255
SM 20 LP-ASTR	M20	420	M22	500	M24	25	270
SM 24 LP-ASTR	M24	730	M27	890	M30	35	310
SM 30 LP-ASTR	M30	1 460	M33	1 745	M36	60	475
SM 36 LP-ASTR	M36	2 570	M39	3 000	M42	90	1 000
SM 42 LP-ASTR	M42	4 125	M45	4 995	M48	120	1 625

1) Torque values are valid for bolts with metric thread, material grade 8.8, yield strength >640 N/mm<sup>2</sup>, oil lubricated thread courses and nut mating surfaces without slide additives.  
 2) Optional bolt size. For an engineered solution, please contact [vibracon@skf.com](mailto:vibracon@skf.com).  
 3) Machine load is the sum of the weight of the component and the dynamic forces on the SKF Vibracon for the heaviest loaded position, multiplied by a safety factor.  
 4) Proof load is the tested load which can be applied on the SKF Vibracon chock at maximum height before plastic deformation will occur. Exceeding the proof load will permanently deform the element, rendering it no longer adjustable. This is a tested load for SKF Vibracon surface treated chocks only.

### Other SKF Vibracon applications

The configurations and materials of SKF Vibracon chocks are not limited to the examples shown in the product tables. Many options are available and routinely deployed to solve mounting challenges.



**Shock hardened**  
Elements for the Grade A Shock (MIL-S-901D) requirements.



**Extended SKF Vibracon chocks or additional bottom rings**  
For installations with larger gaps between machine foot and foundation. The maximum extended height should not exceed the diameter of the chock.



**Customised chocks**  
With SKF Vibracon knowledge a solution can be provided for virtually every mounting challenge, even when the bolt pitch is limited or in case of special material requirements.



**SKF Vibracon kit for resilient mounts**  
A one-box kit solution for commonly used resilient mounts.



#### Technical data

Designation	SKF Vibracon Type range
SMAT 006	SM 12 – SM 16
SMAT 008	SM 20 – SM 24
SMAT 010	SM 30 – SM 48
SMAT 012	SM 56 – SM 64
SMAT 006 LP-3	SM 12 LP – SM 20 LP
SMAT 006 LP-4	SM 24 LP – SM 42 LP

### SKF Vibracon adjustment tools

The use of SKF Vibracon chocks brings efficiency and cost savings to the installation of rotating components. A good set of tools will simplify the installation. The SKF Vibracon adjustment tools are especially designed for safe height alteration of the SKF Vibracon chocks with comfort.

[skf.com](http://skf.com) | [mapro.skf.com](http://mapro.skf.com) | [skfvibracon.com](http://skfvibracon.com)

© SKF is a registered trademark of the SKF Group.  
App Store is a service mark of Apple Inc. registered in the US and other countries.  
Android and Google Play are trademarks of Google Inc.

© SKF Group 2017  
The contents of this publication are the copyright of the publisher and may not be reproduced (even extracts) unless prior written permission is granted. Every care has been taken to ensure the accuracy of the information contained in this publication but no liability can be accepted for any loss or damage whether direct, indirect or consequential arising out of the use of the information contained herein.

PUB MP/P8 17660 EN · November 2017

This publication supersedes publications PUB 43/P8 06686/4 EN , PUB 43/P2 14497/1 EN and PUB 43/P8 15264 EN